

*Quando la potenza diventa silenziosa.*

# Hercules

Sblocco manuale  
Manual release  
Desbloqueo manual

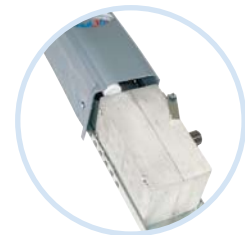

Assolutamente silenzioso  
Absolutely noiseless  
Absolutamente silencioso

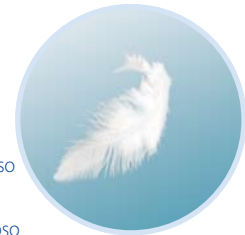

**OK-H250** 230Vac max 1,25m (x2)

## DATI TECNICI

Alimentazione  
Potenza assorbita (W)  
Assorbimento motore (A)  
Condensatore incorporato (µF)  
Grado di protezione (IP)  
Velocità albero motore (rpm)  
Velocità albero d'uscita (rpm)  
Rapporto di riduzione  
Tempo di apertura (s)  
Temp. di esercizio (°C Min/Max)  
Ciclo di lavoro (%)  
Peso motore (kg)  
Classe di isolamento  
Termoprotezione (°C)  
Lunghezza max anta (cm)

## TECHNICAL FEATURES

Power  
Power absorbed (W)  
Current absorbed (motor) (A)  
Incorporated capacitor (µF)  
Protection level (IP)  
Motor shaft speed (rpm)  
Output shaft speed (rpm)  
Reduction ratio  
Opening time (s)  
Working temp. (°C Min/Max)  
Work cycle (%)  
Motor weight (kg)  
Insulation class  
Thermal cut-out (°C)  
Maximum leaf length (cm)

## DATOS TECNICOS

Alimentación  
Potencia absorbida (W)  
Absorción motor (A)  
Condensador (µF)  
Grado de protección (IP)  
Velocidad del eje del motor (rpm)  
Velocidad del eje de salida (rpm)  
Relación de reducción  
Tiempos de apertura (s)  
Temp. de servicio (°C Min./Máx)  
Ciclo de trabajo (%)  
Peso motor (kg)  
Clase de aislamiento  
Protección térmica (°C)  
Longitud máxima de la hoja (cm)

OK-H250
230Vac 50Hz
250
1,3
10
44
1400
1,7
1/820
15
-30/+70
60
9,5
F
140
125+125

Disponibile anche in 110 V / Also available in 110V / También disponible en 110 V

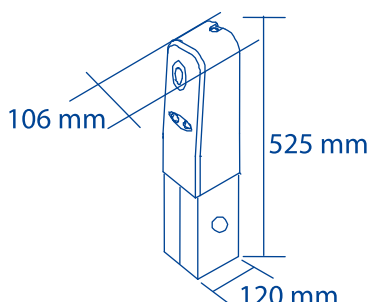

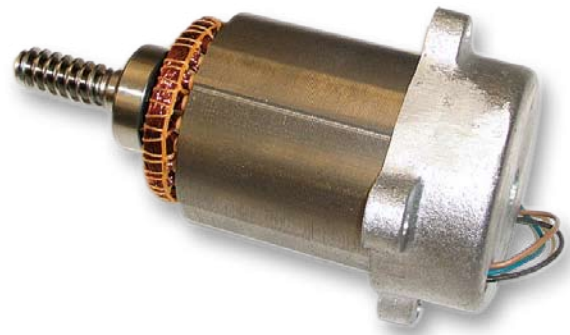

COMPONENTI  
COMPONENTS  
COMPONENTES

*When power becomes **silence**.*



**QK-CE220RLIND**

Centrale QK-CE220RL in scatola con pulsanti di comando incorporati

*QK-CE220RL control board in box with built-in command pushbuttons*

Cuadro eléctrico QK-CE220RL en la caja con pulsadores de mando incorporados

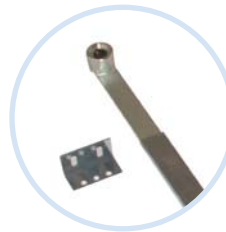

**QK-BTL**

Braccio telescopico laterale

*Telescopic lateral arm*

Brazo lateral telescópico



**QK-MANO**

Meccanismo di sblocco manuale

*Manual release mechanism*

Mecanismo de desbloqueo manual



Per altri optional andare alla relativa pagina del catalogo

*For other optional go to the relative page of the catalogue*

Para otros optional ir a la relativa página del catalogo.



La serie di automatismi HERCULES di QUIKO è la giusta scelta per la movimentazione di svariati tipi di portoni industriali. Il modello QK-H250 è adatto all'automatizzazione di portoni a libro a 2+2 ante. I materiali utilizzati per la costruzione, ovvero ghisa, alluminio, bronzo e acciaio, garantiscono la robustezza e l'affidabilità del motoriduttore nel tempo. I motoriduttori QK-H250 sono stati progettati in maniera da essere installati con semplicità e avere un'ottima silenziosità nel funzionamento.

*The HERCULES serie of gearmotors by QUIKO is the right choice for automating various types of industrial doors. Model QK-H250 is suitable for 2+2 folding doors. The materials used for its construction, i.e. iron, aluminium and steel, guarantee robustness and reliability of the gearmotor for long time. QK-H250 has been designed for an easy installation and for an absolutely noiseless working.*

La serie de automatismos HERCULES de QUIKO es la elección adecuada para la movilización de distintos tipos de portones industriales. El modelo QK-H250 es adecuado para la automatización de portones de apertura libro de 2+2 hojas. Los materiales utilizados para la construcción, o bien, el hierro, aluminio y acero, garantizan la robustez y la fiabilidad del motorreductor en el tiempo. QK-H250 ha sido diseñado para poder ser instalados fácilmente y tener un funcionamiento extremadamente silencioso.



**Borinato F.lli Snc**  
Via Seccalegno, 19  
36040 Sossano (VI) - Italy  
Tel. +39 0444 785513  
Fax +39 0444 782371  
**info@quiko.biz**  
**www.quiko.biz**



QUIKO può apportare ai suoi prodotti  
modifiche tecniche, migliorative  
della qualità, senza preavviso.

*QUIKO can technically improve  
the quality of its products without  
any prior notice.*

QUIKO puede mejorar técnicamente  
la calidad de sus productos sin  
ningún aviso anterior.



# Hercules

